

STRONGAR HARDWARE PLUS COLLECTION

FEATURES

- These face mounted door rollers will glide smooth and silent on Nylon-coated wheels so barn doors can be maneuvered effortlessly.
- Suitable for wood or metal doors with a loading capacity of 240 lbs.
- Each roller is equipped with an anti-jump pin that will eliminate the risk of your door shifting or coming off the track, rendering your space safe for all.
- Entirely made of 304 grade Stainless Steel

FINISHES AVAILABLES

- Brushed Satin (S)

PRODUCT SKU

- SHPL-VIC-WF-01

SPECIFICATIONS

- Material: 304 grade Stainless Steel
- Weight Capacity: 220 Lbs.
- Application: wood and metal Doors
- Min & Max. Door Thickness: 1-1/8" – 1-3/4"

DOOR CONFIGURATION

- Single Door, Double Door or Multiple Doors

PERFORMANCE

- Meets requirements for sliding barn doors by exceeding 100,000 cycles in operation

CONSTRUCTION SPECIFICATIONS INSTITUTE (CSI)

- Division 8 – Door and Windows
CSI Code: 08700 – Hardware
CSI Code: 08710 – Door Hardware

INSTALLATION NOTES

- It is the sole responsibility of the purchaser to provide adequate door to accommodate the loading capacity of the rail system.
- All technical advice is subject to alteration based on the job condition.
- Simple to install.

WARRANTY

- One year limited warranty

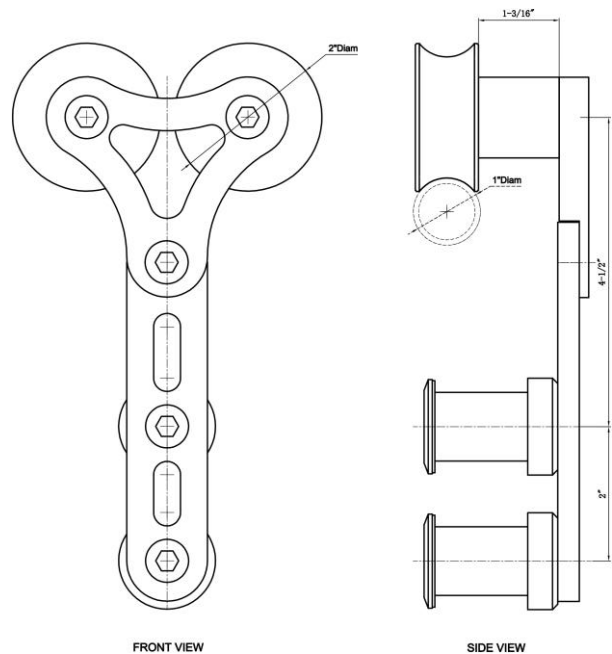

These dimensions and specifications are subject to change without notice